

ASSEMBLY INSTRUCTIONS

NORWOOD SHELVING

DOUBLE FACE

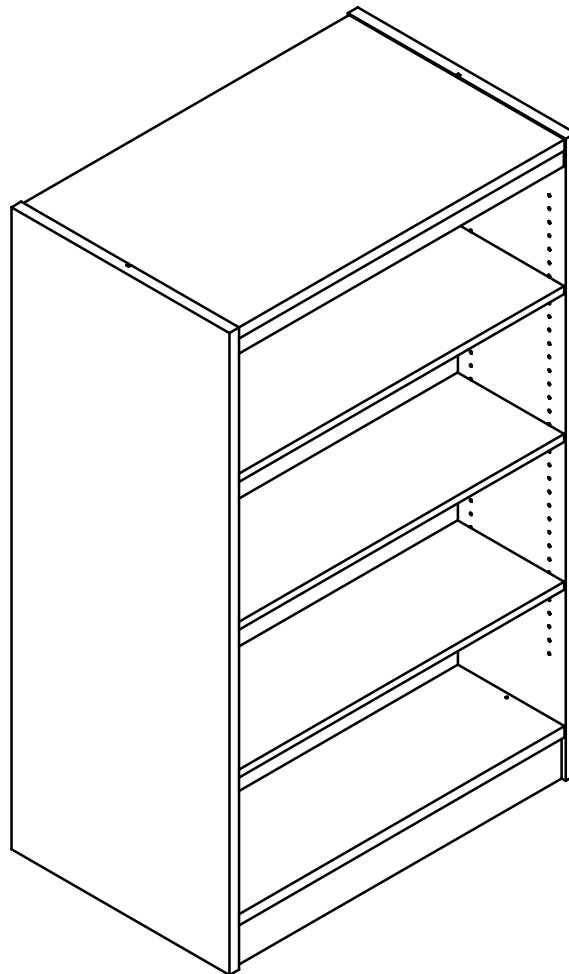

PALMIERI
create. communicate. collaborate.

T 905 731 9300
F 905 731 9878
TF 800 413 4440

www.palmierifurniture.com

NORWOOD DF Shelving Assembly Instructions

Starter Parts

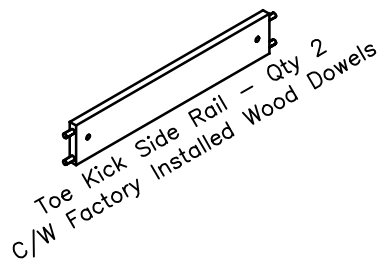
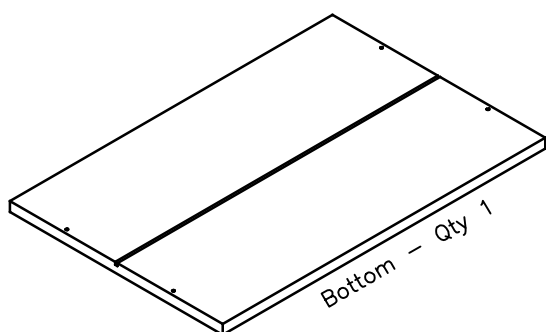
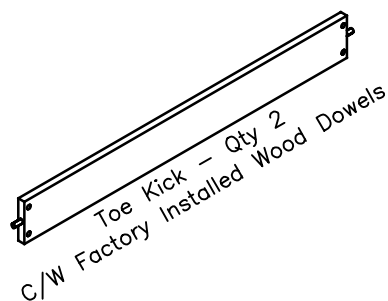
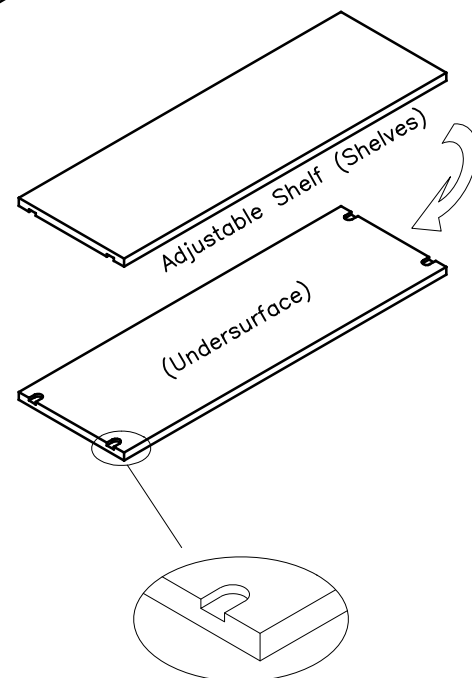
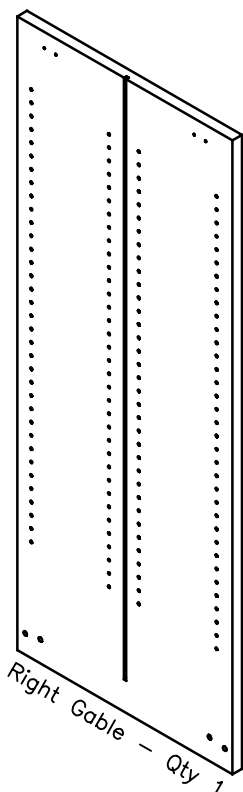
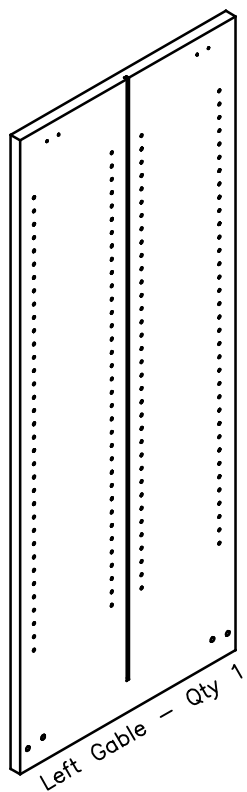
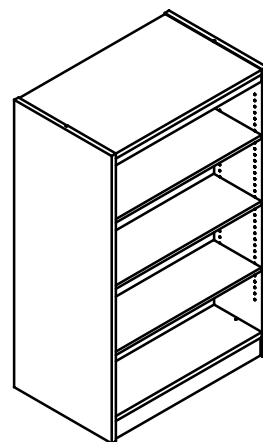
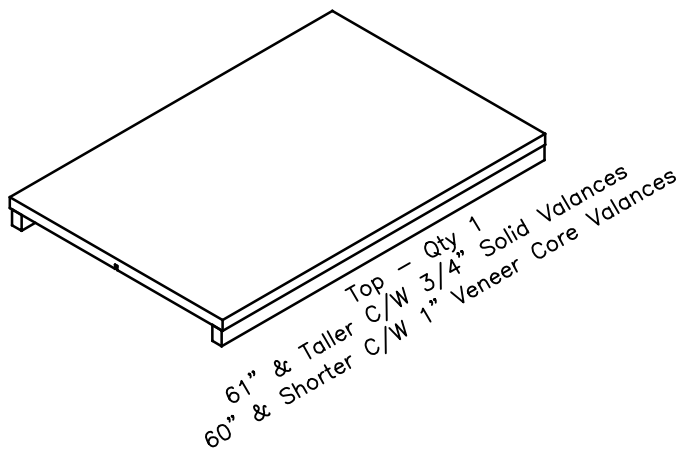

PALMIERI
create. communicate. collaborate.

T 905 731 9300
F 905 731 9878
TF 800 413 4440

www.palmierifurniture.com

NORWOOD DF Shelving Assembly Instructions

Starter Hardware

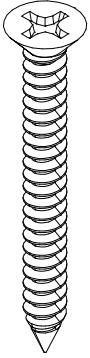
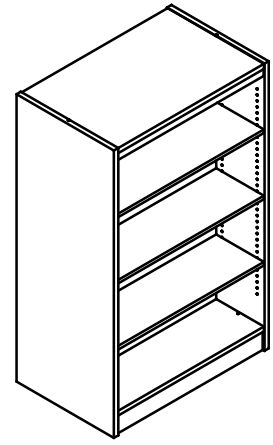

500-002 - Qty 4
#8x1 1/2"L
Flat Head Screw

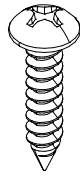

500-005 - Qty 16
#6x5/8"L
Pan Head Bronze Screw



500-001 - Qty 4
1" Finishing Nail



500-004 - Qty 4
1/4-20x2"L
Threaded Rod



500-008
Qty 4 Per Shelf
#10x1 1/4"L
Threaded Adjustable
Shelf Pin

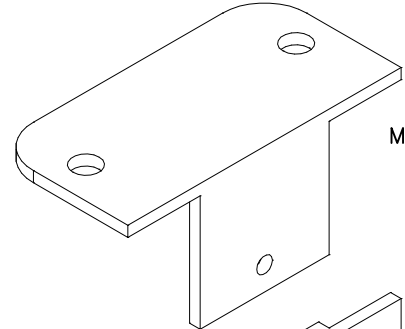

Male

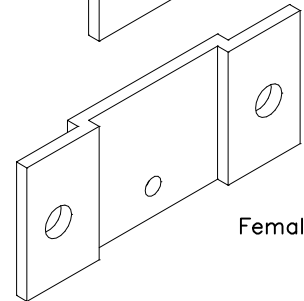

Female

500-055 - Qty 4
Beta Clip Assembly

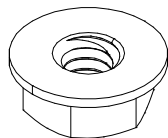

500-003 - Qty 4
1/4-20
Serrated Flange Nut

PALMIERI
create. communicate. collaborate.

T 905 731 9300
F 905 731 9878
TF 800 413 4440

www.palmierifurniture.com

NORWOOD DF Shelving Assembly Instructions

Add-On Parts

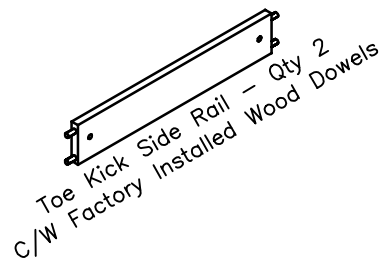
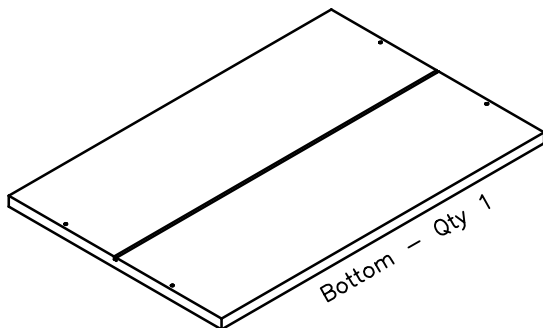
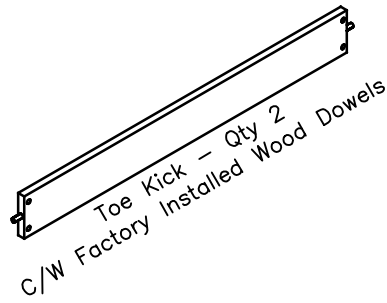
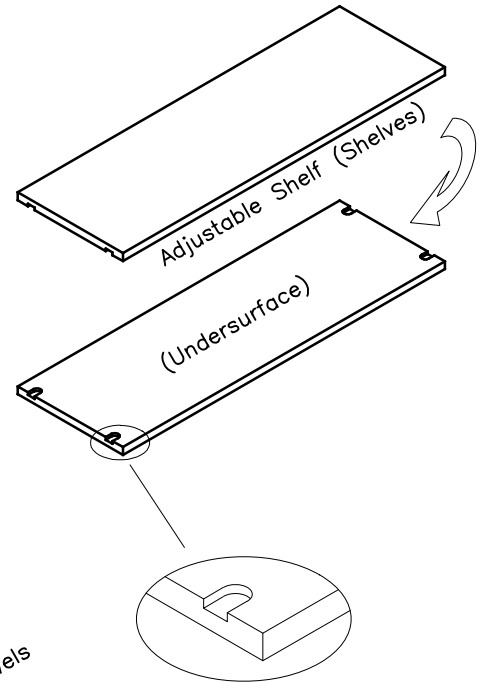
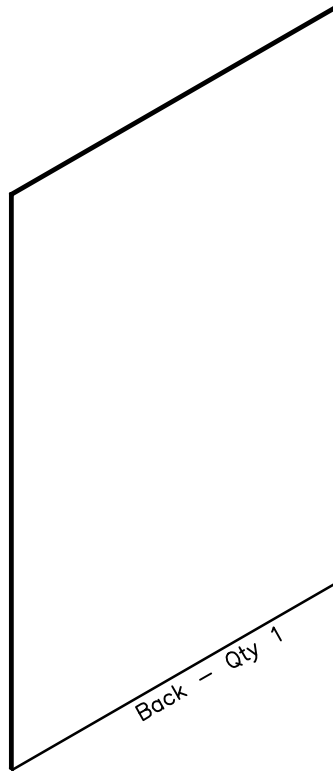
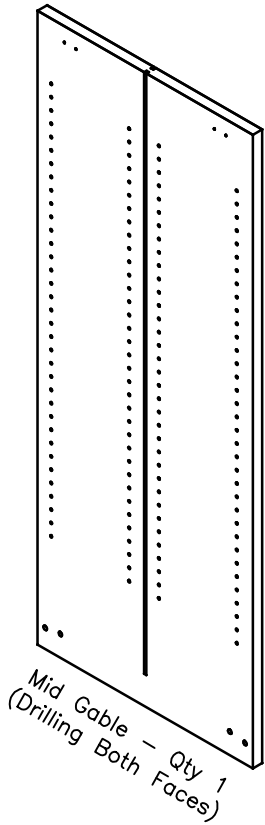
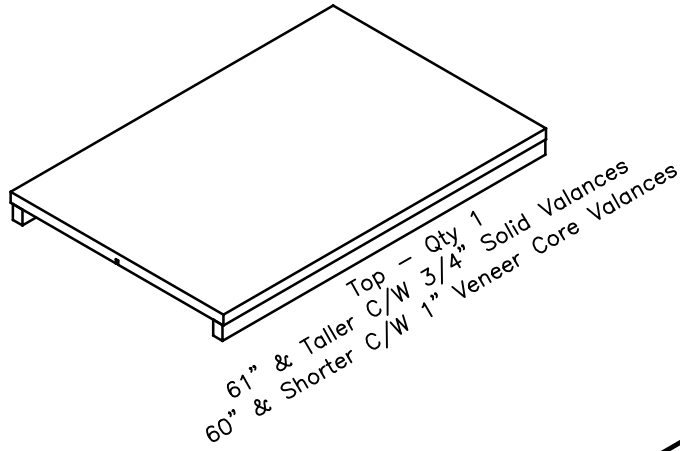
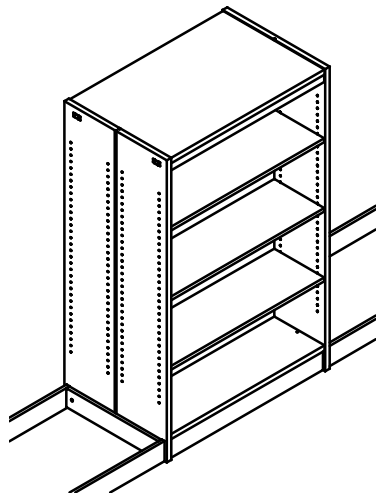

PALMIERI
create. communicate. collaborate.

T 905 731 9300
F 905 731 9878
TF 800 413 4440

www.palmierifurniture.com

NORWOOD DF Shelving Assembly Instructions

Add-On Hardware

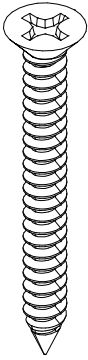
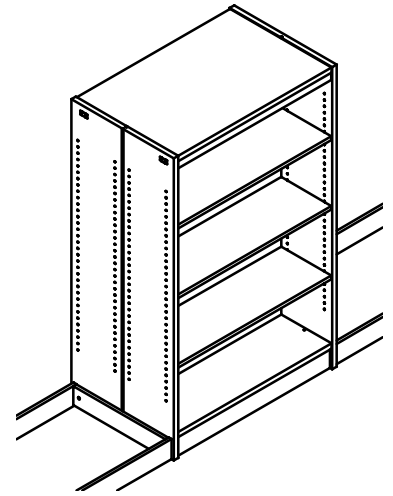

500-002 – Qty 4
#8x1 1/2" L
Flat Head Screw

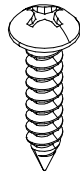

500-005 – Qty 16
#6x5/8" L
Pan Head Bronze Screw



500-001 – Qty 4
1" Finishing Nail

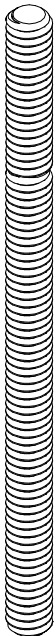

500-056 – Qty 2
1/4-20x4" L
Threaded Rod



500-008
Qty 4 Per Shelf
#10x1 1/4" L
Threaded Adjustable
Shelf Pin

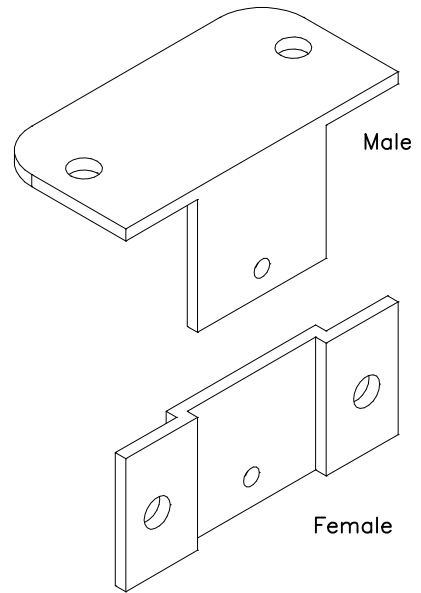

500-055 – Qty 4
Beta Clip Assembly

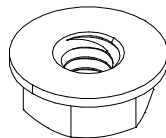

500-003 – Qty 4
1/4-20
Serrated Flange Nut

PALMIERI
create. communicate. collaborate.

T 905 731 9300
F 905 731 9878
TF 800 413 4440

www.palmierifurniture.com

1 - BASE ASSEMBLY

Assemble Front And Rear Toe Kicks to Toe Kick Side Rails Using (8) Factory Installed Wood Dowels.

When Assembled, Top Edges Will Be Flush.

Complete Assembly Is A Dry Fit.

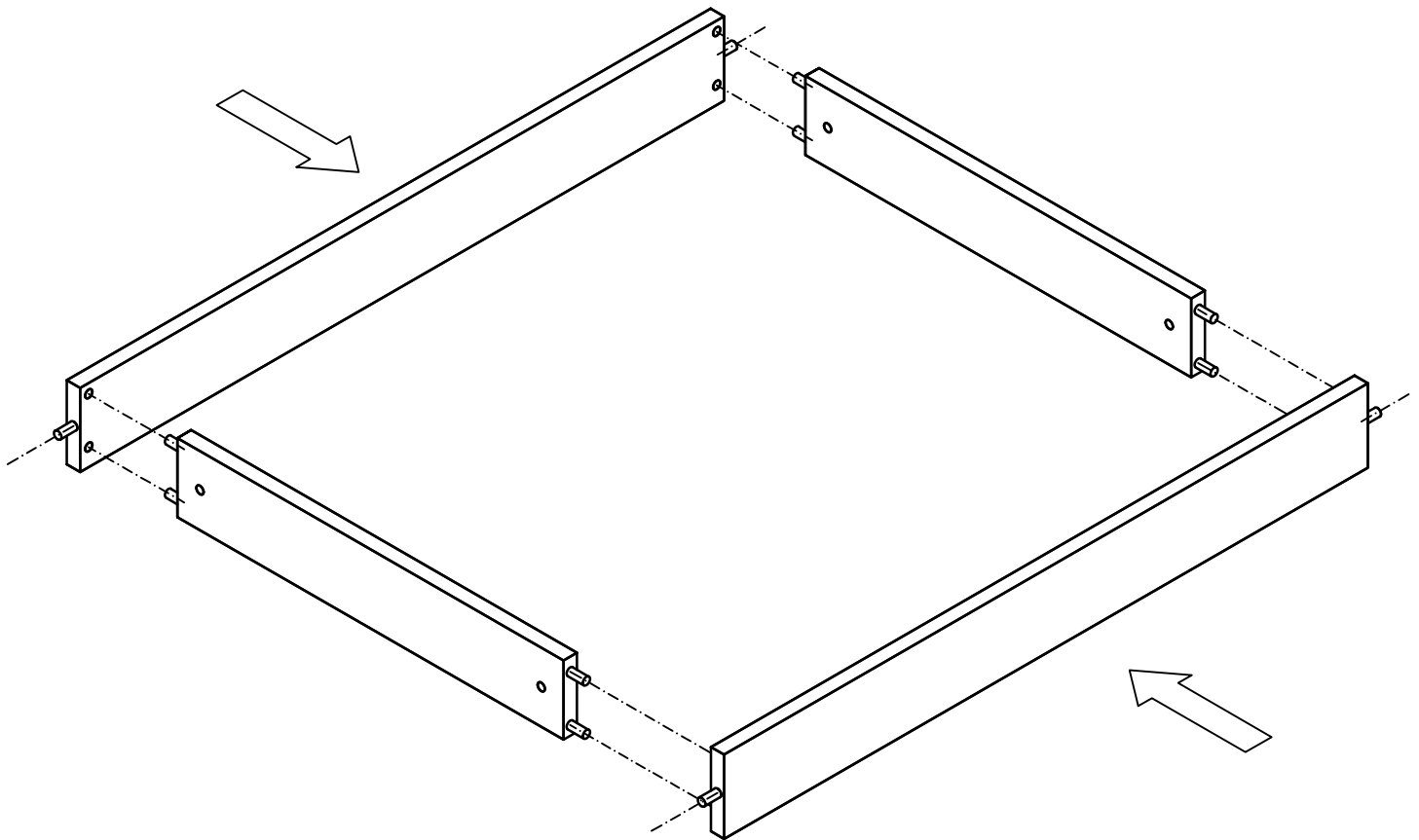

PALMIERI
create. communicate. collaborate.

T 905 731 9300
F 905 731 9878
TF 800 413 4440

www.palmierifurniture.com

2 - GABLE ASSEMBLY

Starter

Install (2) Female Beta Clips To Each Gable Using (2) #6x5/8"L Pan Head Bronze Screws.

Install Toe Kick/Rail Assembly To Both Gables Using (4) 1/4-20x2"L Threaded Rods With Serrated Flange Nuts And (4) Factory Installed Wood Dowels.

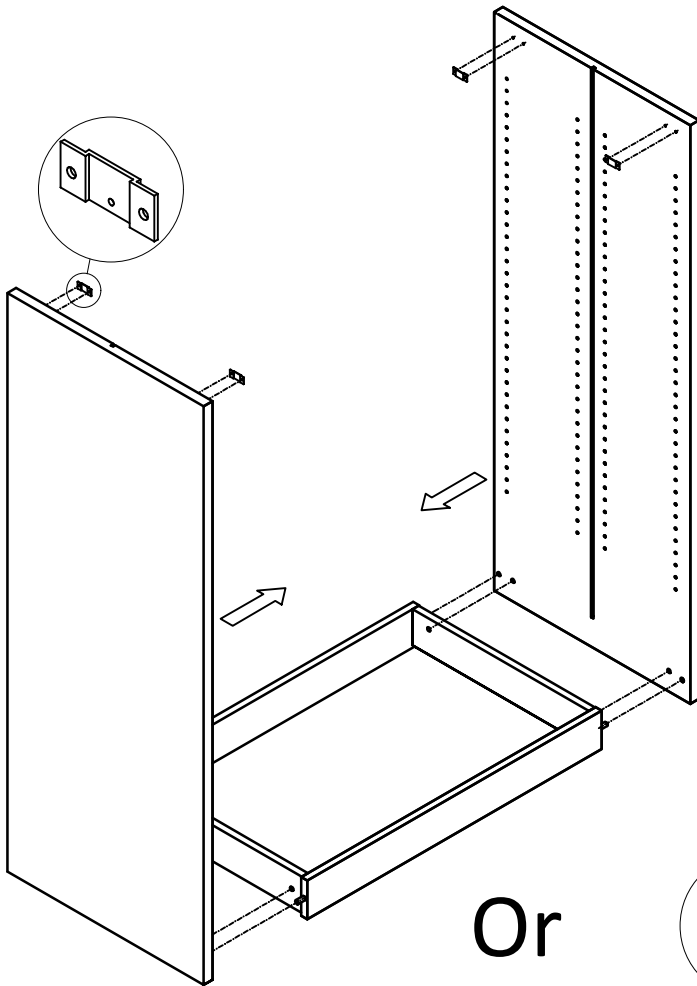

Or

Add-On

Install (2) Female Beta Clips To Each Side Of The Gable Using (2) #6x5/8"L Pan Head Bronze Screws.

Install Toe Kick/Rail Assembly To Gable Using (2) 1/4-20x4" Threaded Rods With Serrated Flange Nuts And (4) Factory Install Wood Dowels.

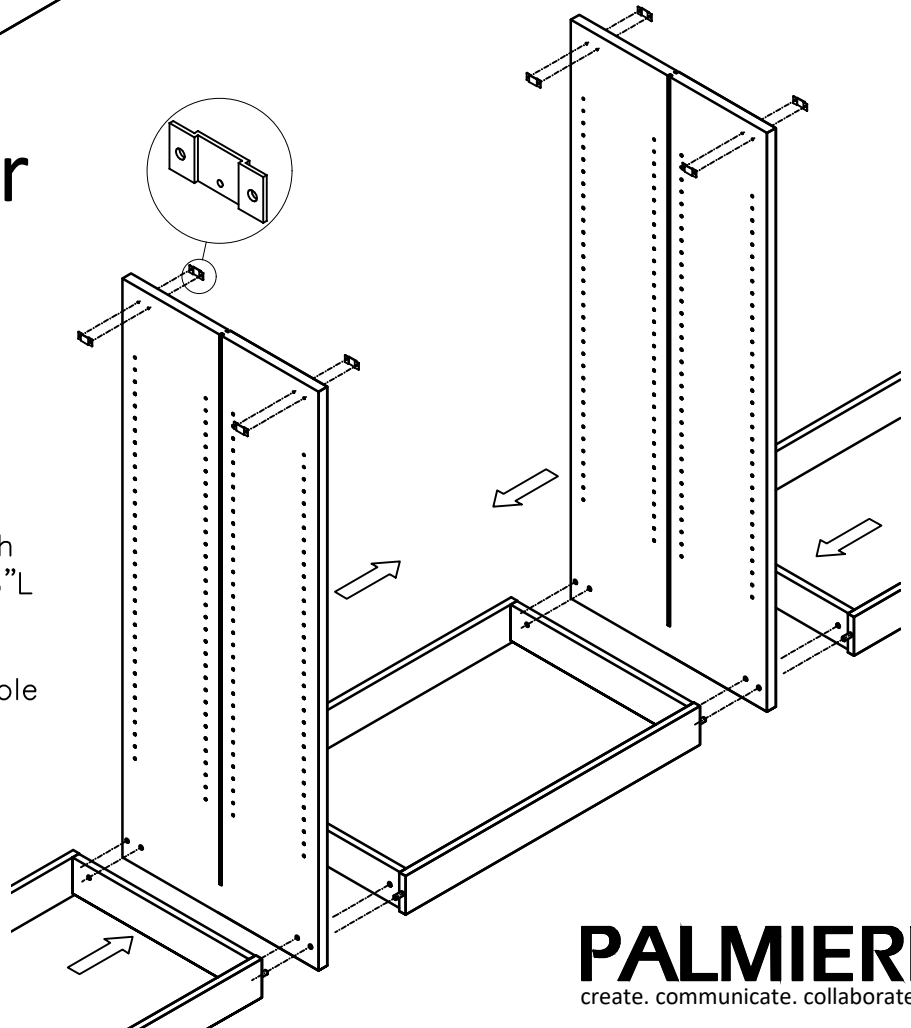

PALMIERI
create. communicate. collaborate.

T 905 731 9300
F 905 731 9878
TF 800 413 4440

www.palmierifurniture.com

3 - BACK & BOTTOM ASSEMBLY

Starter And Add-On

Place Bottom Onto Toe Kick/Rail Assembly.

Install Back Panel Into Gable Grooves And Slide Down Into The Groove In The Bottom.

Secure Bottom To Toe Kick/Rail Assembly Using (4) #8x1 1/2"L Flat Head Screws.

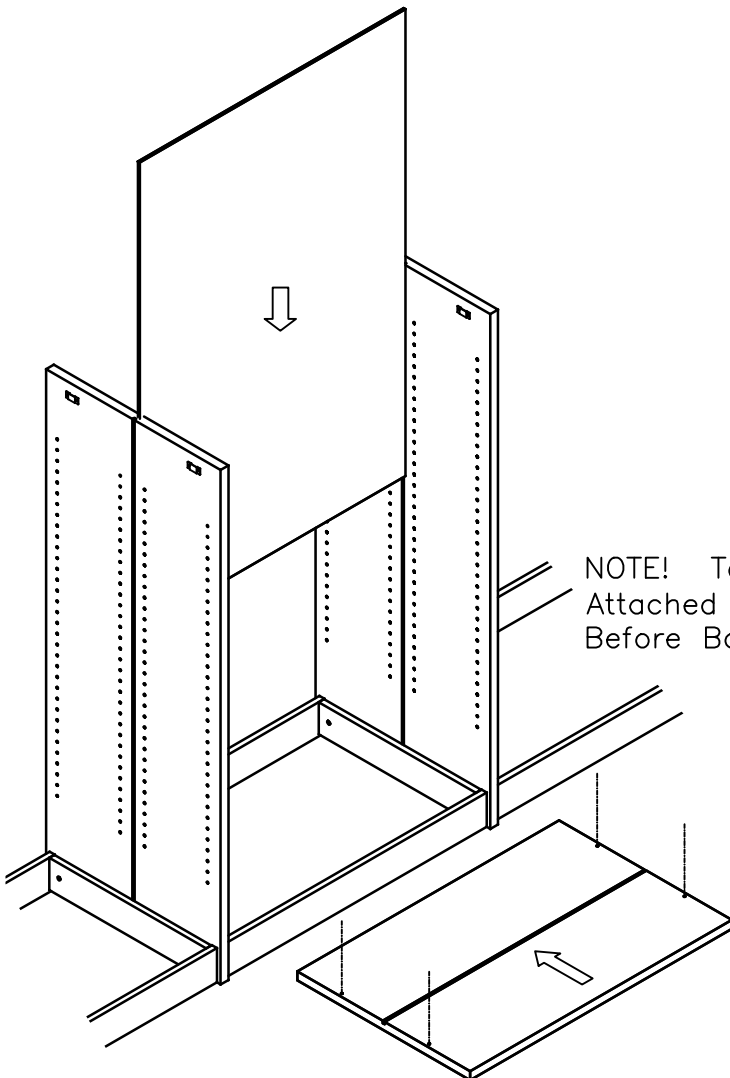
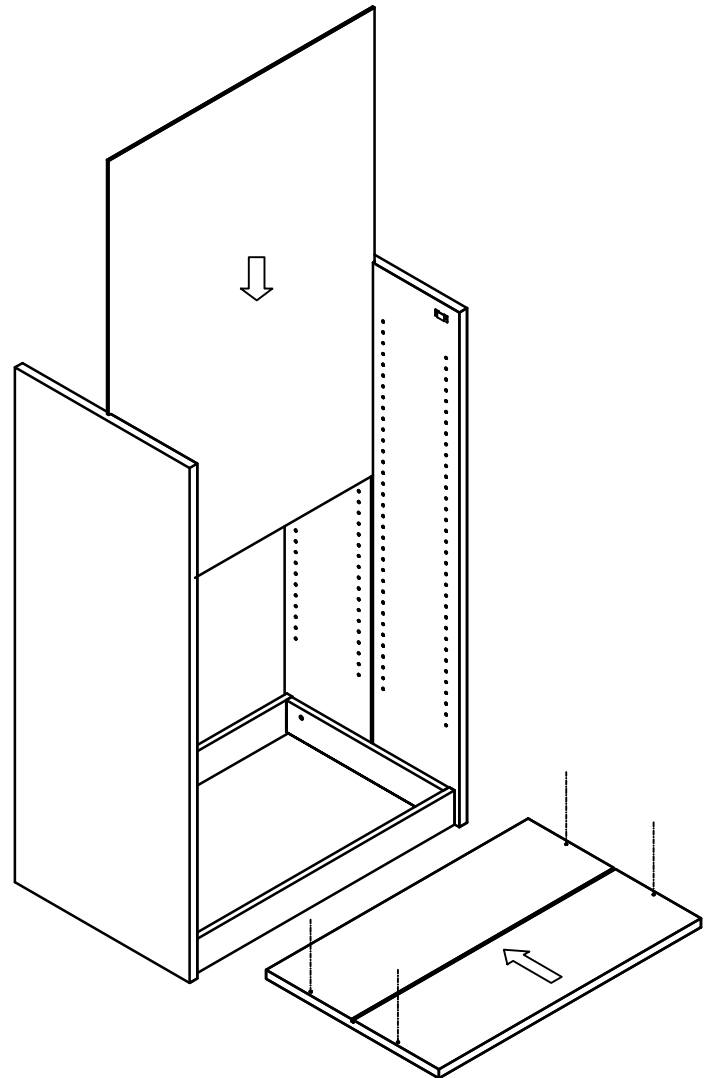

NOTE! Toe Kick/Rail Assembly Must Be Attached To Both Sides Of The Gable Before Bottom And Back Are Installed.

PALMIERI
create. communicate. collaborate.

T 905 731 9300
F 905 731 9878
TF 800 413 4440

www.palmierifurniture.com

4 - TOP ASSEMBLY

Starter And Add-On

Install (4) Male Beta Clips Onto
Top/Valance Assembly Using (2)
#6x5/8"L Pan Head Bronze Screws.

Assemble Top To Gables Using The Beta
Clips. Ensure The Back Panel Is Fitted
Into The Groove On The Underside Of
The Top.

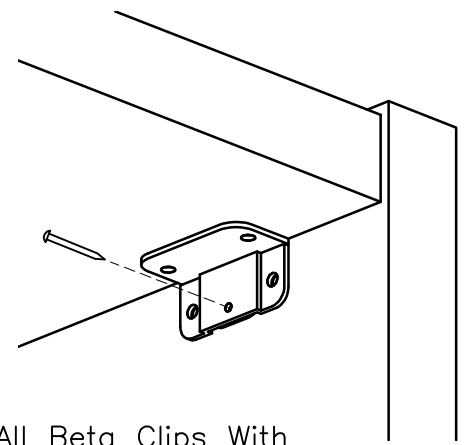
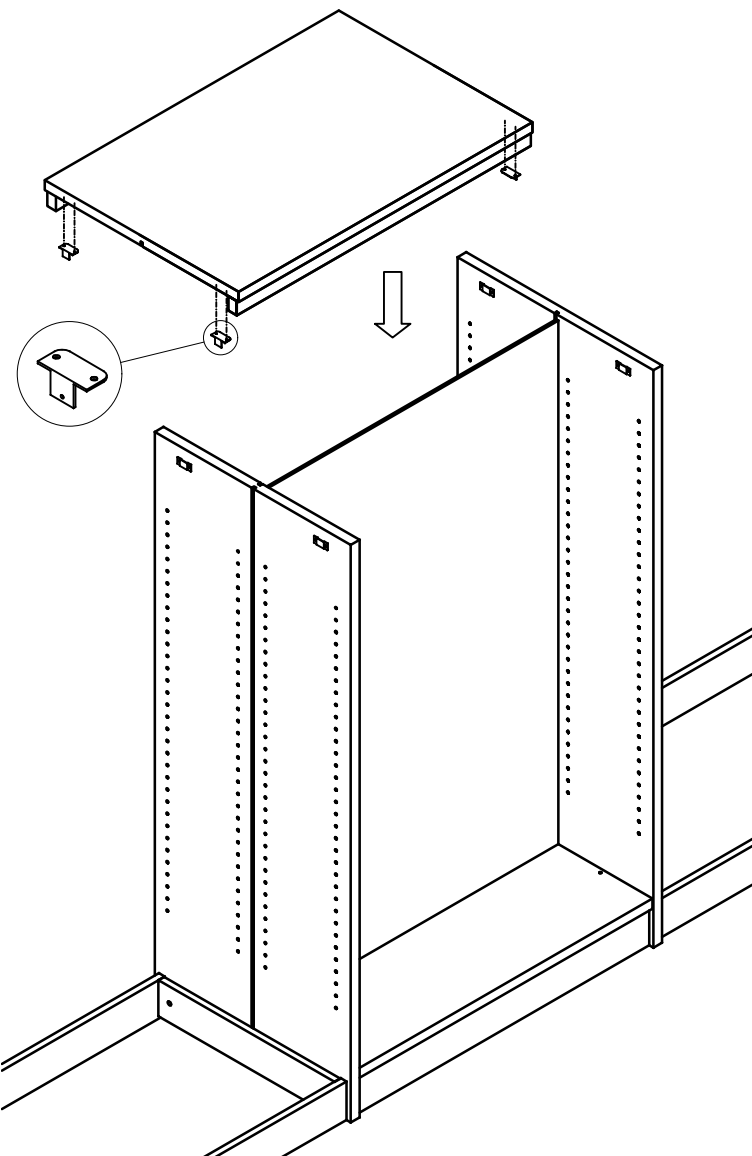
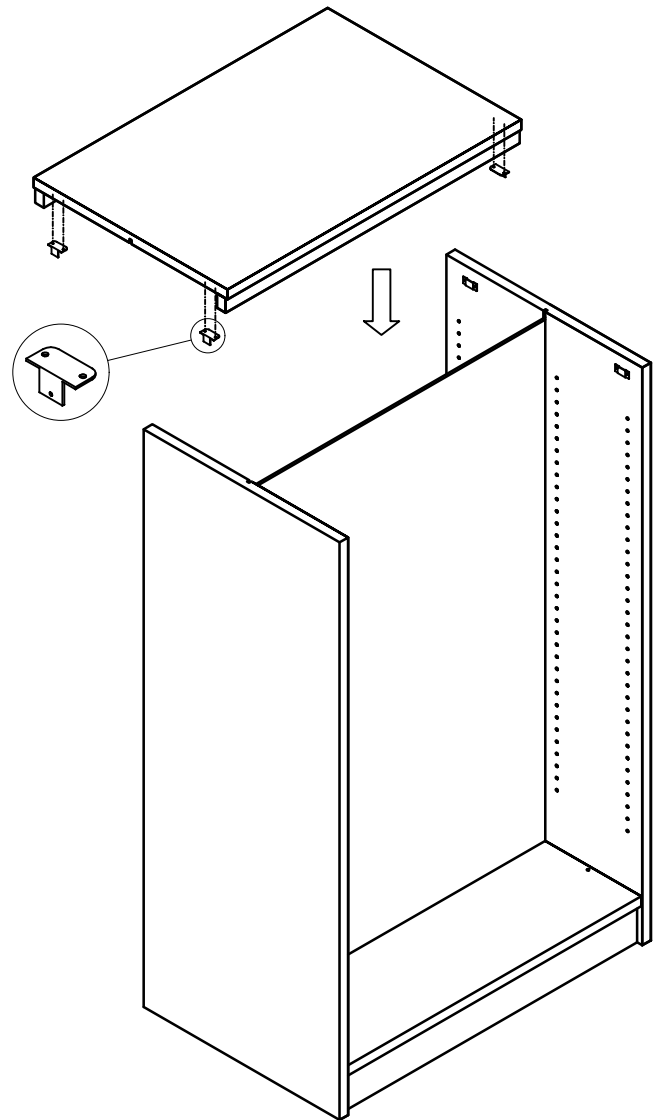

Lock All Beta Clips With
(1) 1" Finishing Nail.

PALMIERI
create. communicate. collaborate.

T 905 731 9300
F 905 731 9878
TF 800 413 4440

www.palmierifurniture.com

5A - FIXED WOOD SHELF ASSEMBLY

FOR WOOD SHELVING UNITS 60”H AND TALLER, ONLY

(SKIP THIS STEP IF YOUR SHELVING UNITS ARE SHORTER THAN 60”H)

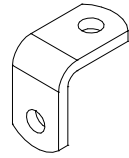
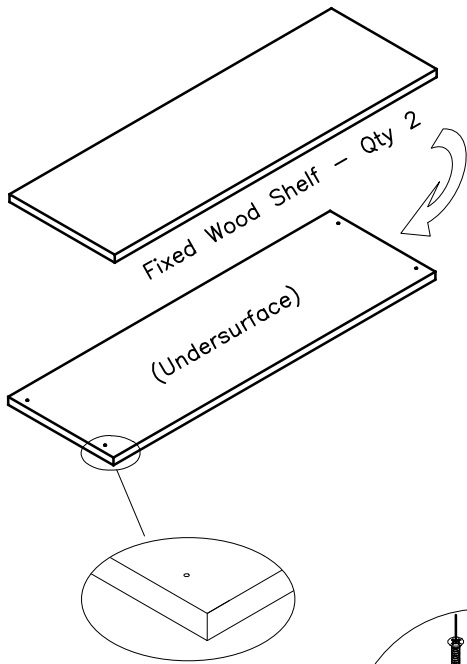

500-060 - Qty 8
L Clip



500-150 - Qty 8
#8x3/4”L
Flat Head Screw



500-015 - Qty 8
5MM Euro Screw

Starter And Add-On

Install (4) L Clips To Fixed Wood Shelf Using #8x3/4”L Flat Head Screw.

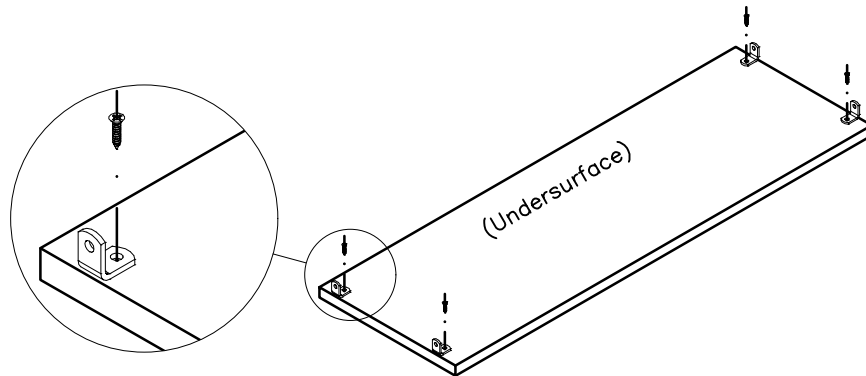

Install Fixed Wood Shelves To Gables Using (4) 5mm Euro Screws Into Existing Adjustable Shelf Pin Holes. Fixed Wood Shelves To Be Placed At Center Of The Gable Height $\pm 2 \frac{1}{2}$ ”.

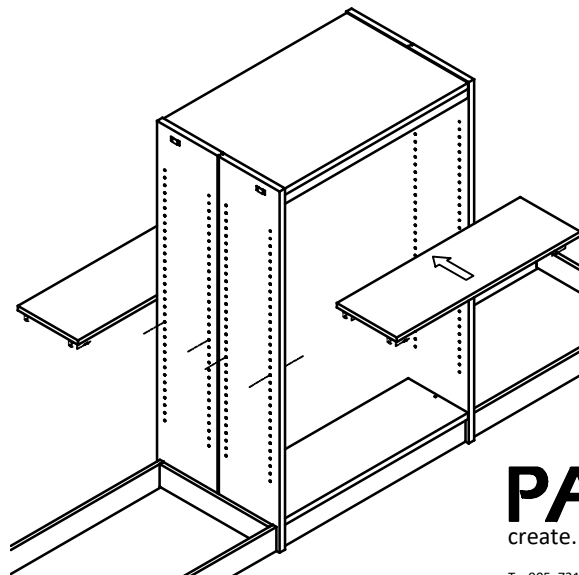
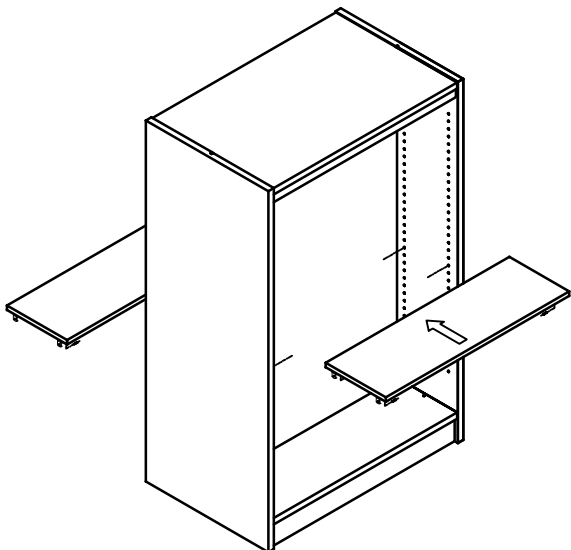

PALMIERI
create. communicate. collaborate.

T 905 731 9300
F 905 731 9878
TF 800 413 4440

www.palmierifurniture.com

6 - ADJUSTABLE SHELF ASSEMBLY

Starter And Add-On

Install Threaded Adjustable Shelf Pins (4 Per Shelf) Into The Gables. Place Adjustable Shelf (Shelves) On Pins.

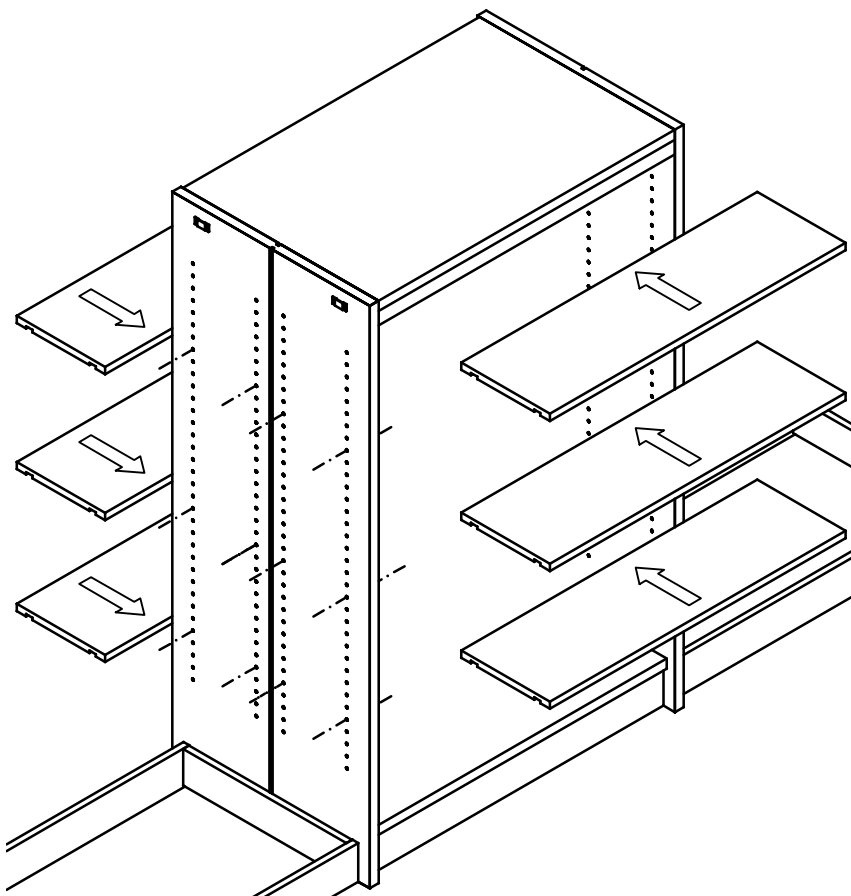
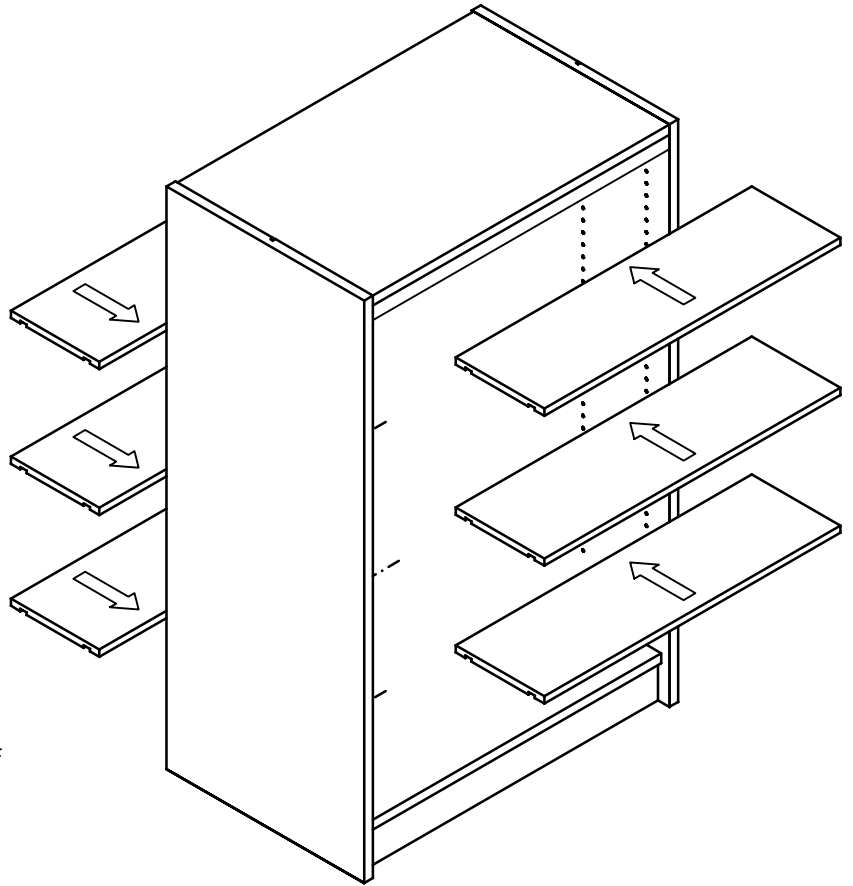

PALMIERI
create. communicate. collaborate.

T 905 731 9300
F 905 731 9878
TF 800 413 4440

www.palmierifurniture.com

7

Starter

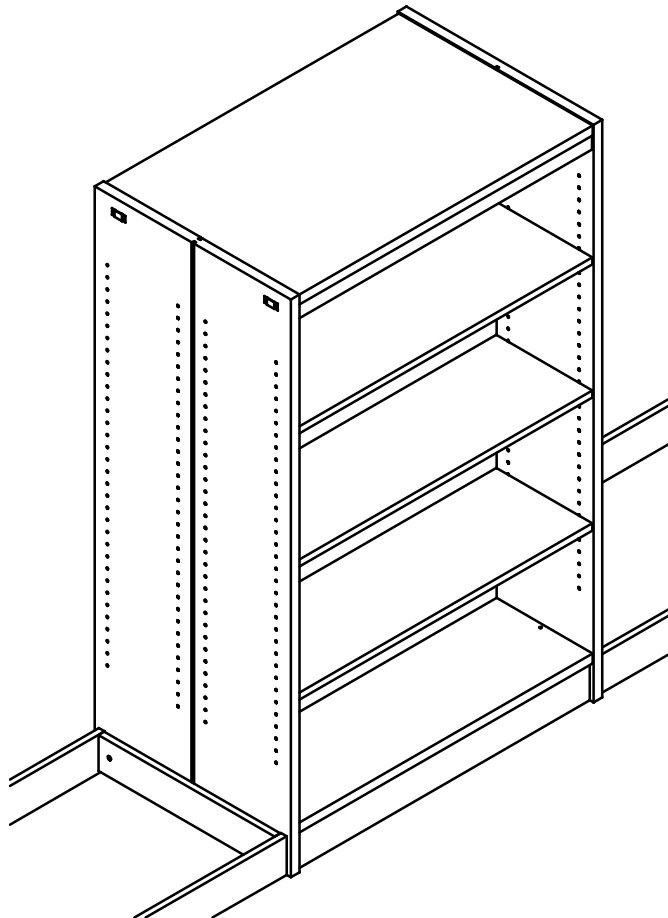
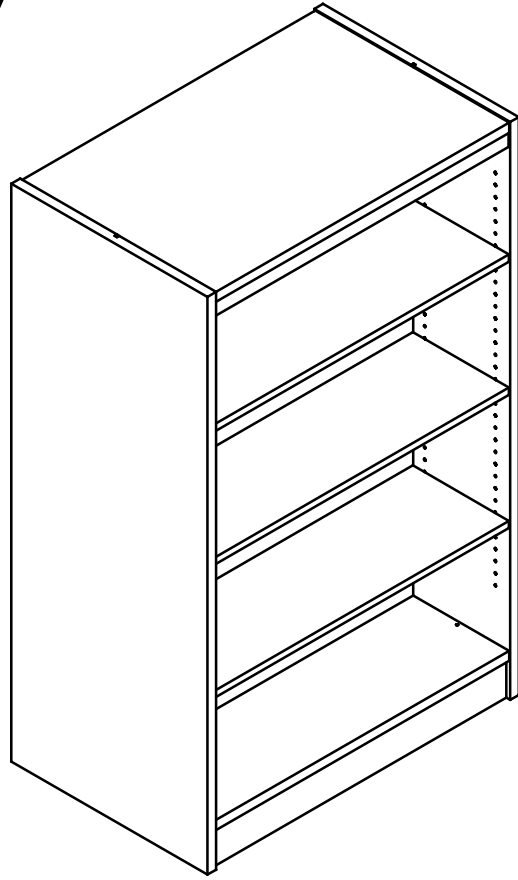

Add-On

PALMIERI
create. communicate. collaborate.

T 905 731 9300
F 905 731 9878
TF 800 413 4440

www.palmierifurniture.com

ASSEMBLY INSTRUCTIONS

NORWOOD SHELVING SINGLE FACE

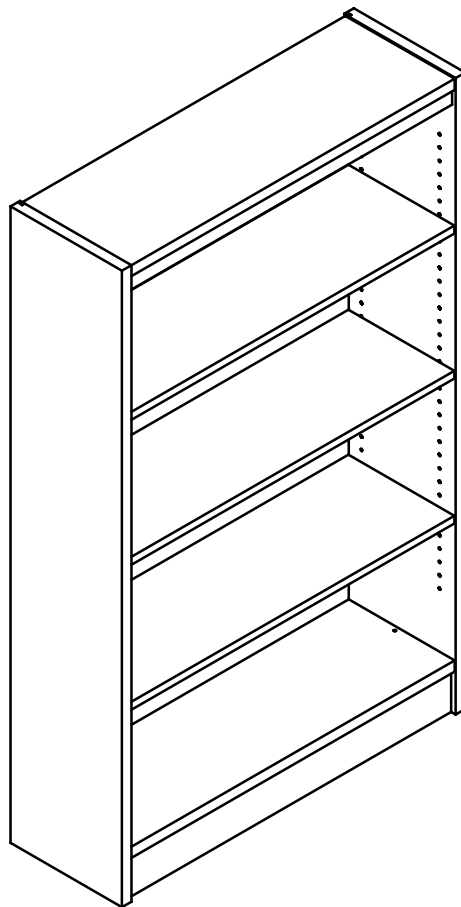

PALMIERI
create. communicate. collaborate.

T 905 731 9300
F 905 731 9878
TF 800 413 4440

www.palmierifurniture.com

NORWOOD SF Shelving Assembly Instructions

Starter Parts

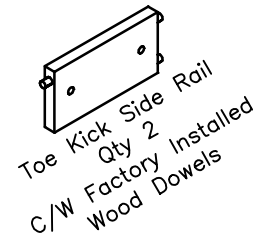
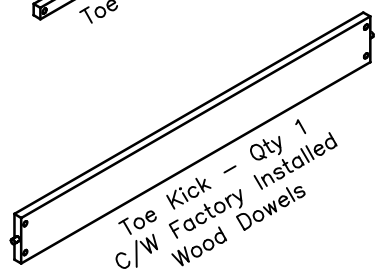
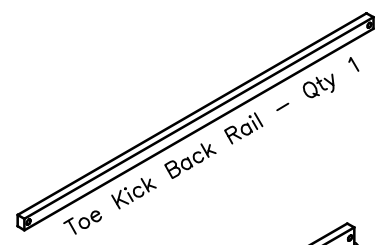
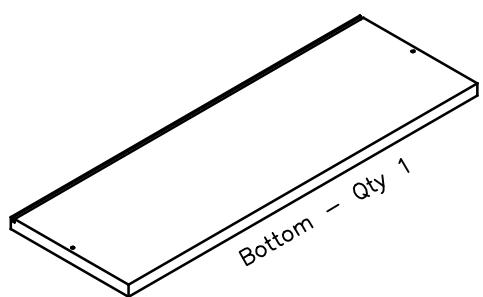
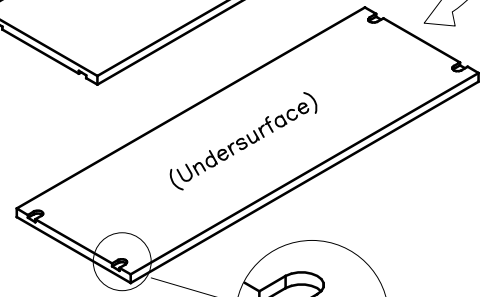
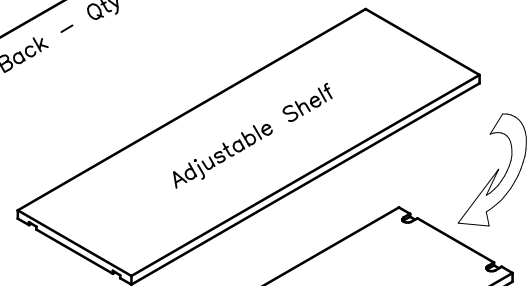
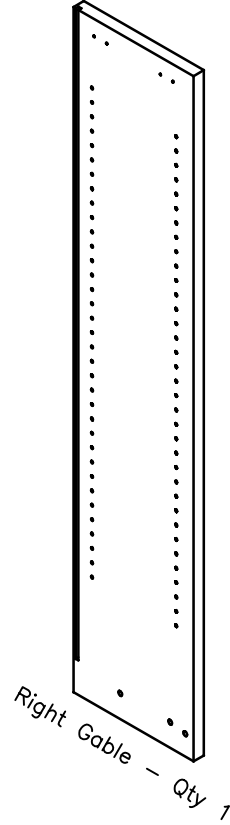
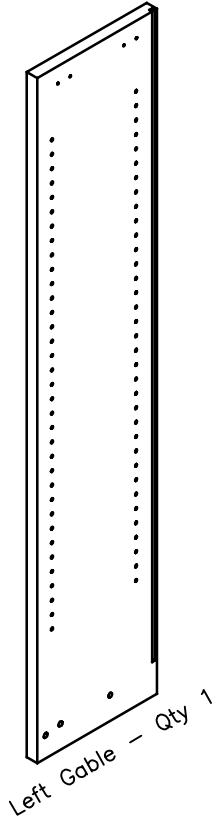
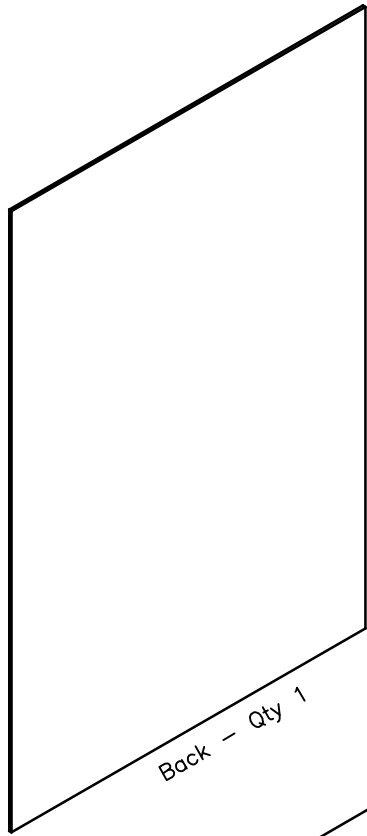
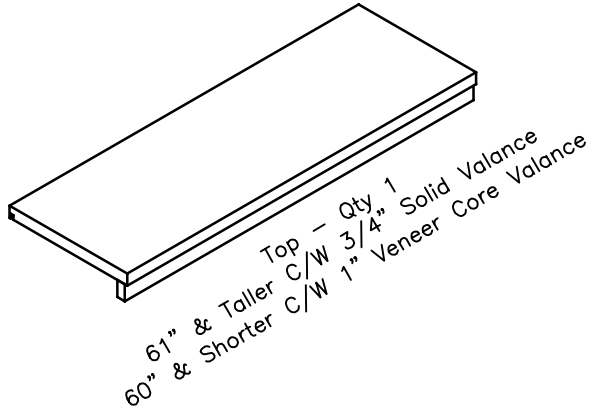
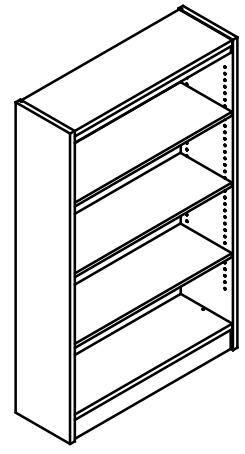

PALMIERI
create. communicate. collaborate.

T 905 731 9300
F 905 731 9878
TF 800 413 4440

www.palmierifurniture.com

NORWOOD SF Shelving Assembly Instructions

Starter Hardware

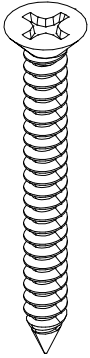
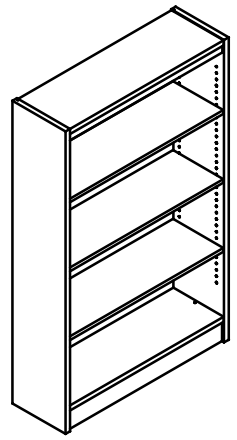

500-002 - Qty 2
#8x1 1/2"L
Flat Head Screw

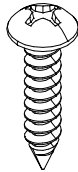

500-005 - Qty 16
#6x5/8"L
Pan Head Bronze Screw



500-001 - Qty 4
1" Finishing Nail



500-004 - Qty 4
1/4-20x2"L
Threaded Rod



500-008
Qty 4 Per Shelf
#10x1 1/4"L
Threaded Adjustable
Shelf Pin

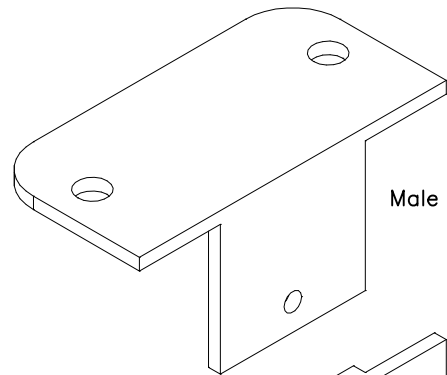

Male

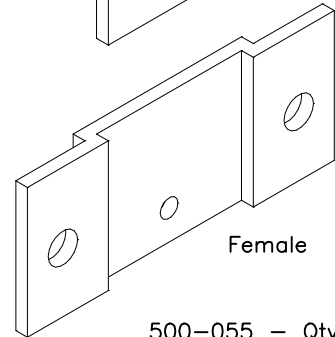

Female

500-055 - Qty 4
Beta Clip Assembly

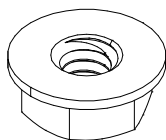

500-003 - Qty 4
1/4-20
Serrated Flange Nut

PALMIERI
create. communicate. collaborate.

T 905 731 9300
F 905 731 9878
TF 800 413 4440

www.palmierifurniture.com

NORWOOD SF Shelving Assembly Instructions

Add-On Parts

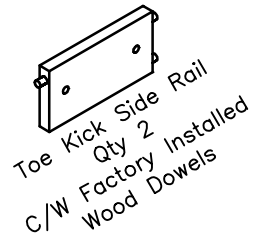
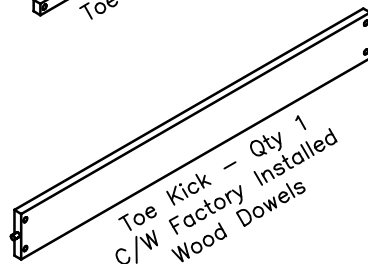
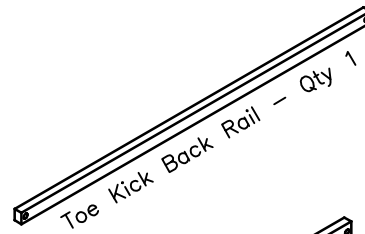
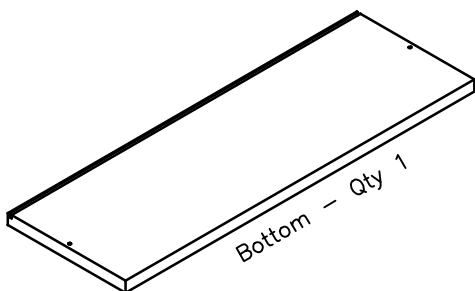
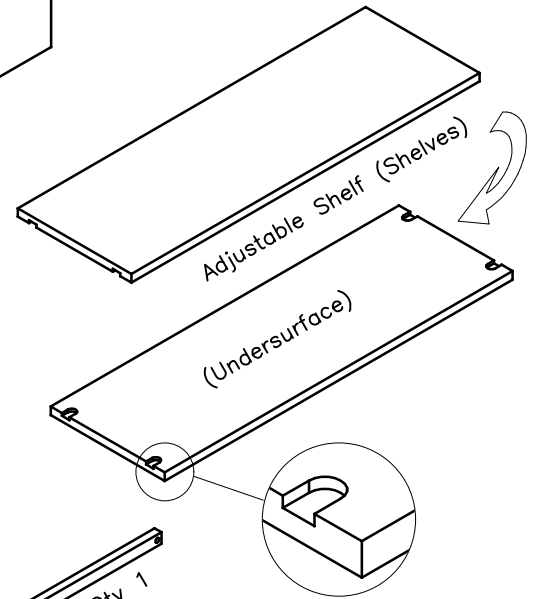
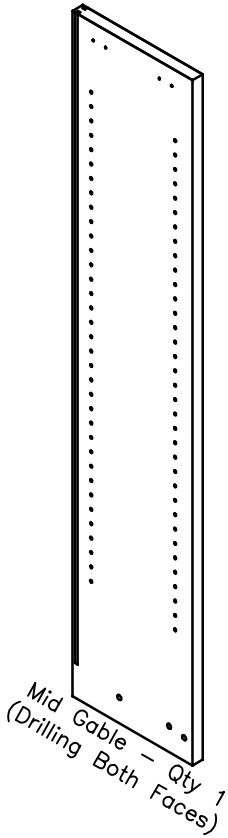
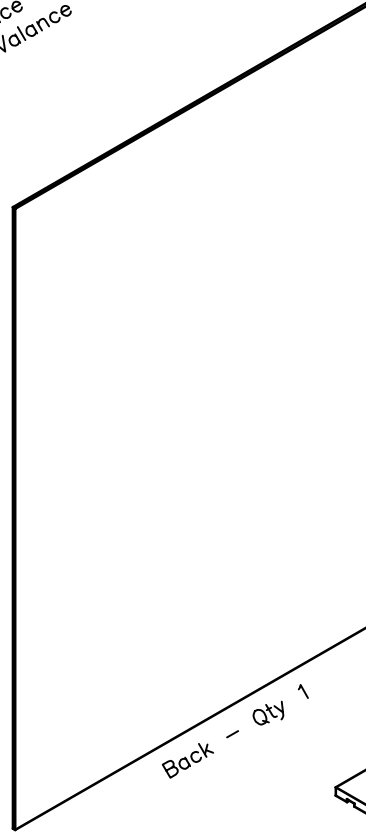
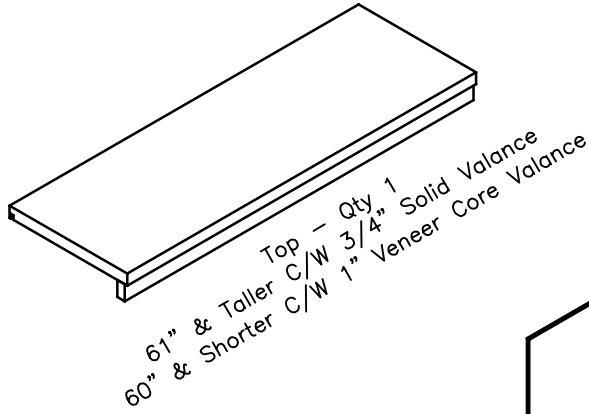
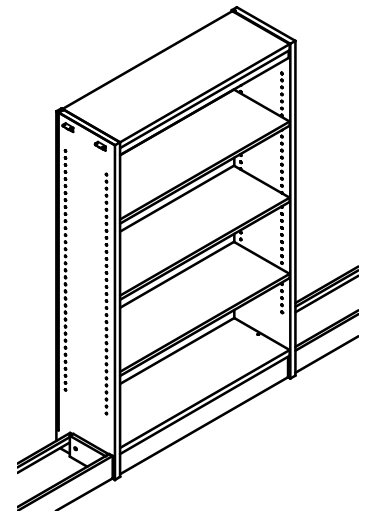

PALMIERI
create. communicate. collaborate.

T 905 731 9300
F 905 731 9878
TF 800 413 4440

www.palmierifurniture.com

NORWOOD SF Shelving Assembly Instructions

Add-On Hardware

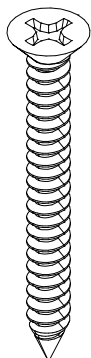

500-002 - Qty 2
#8x1 1/2"L
Flat Head Screw

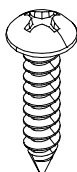

500-005 - Qty 16
#6x5/8"L
Pan Head Bronze Screw



500-001 - Qty 4
1" Finishing Nail

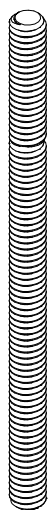
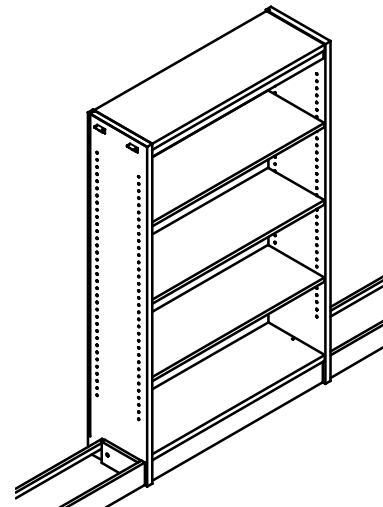

500-056 - Qty 2
1/4-20x4"L
Threaded Rod

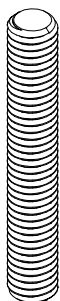

500-008
Qty 4 Per Shelf
#10x1 1/4"L
Threaded Adjustable
Shelf Pin

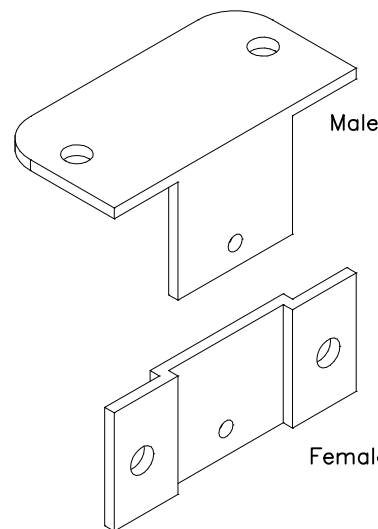

500-055 - Qty 4
Beta Clip Assembly

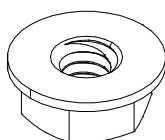

500-003 - Qty 4
1/4-20
Surrated Flange Nut

PALMIERI
create. communicate. collaborate.

T 905 731 9300
F 905 731 9878
TF 800 413 4440

www.palmierifurniture.com

1 - BASE ASSEMBLY

Assemble Toe Kick And Toe Kick Back Rail to Toe Kick Side Rails Using (6) Factory Installed Wood Dowels.

When Assembled, Top Edges of Sides & Front Will Be Flush.

Complete Assembly Is A Dry Fit.

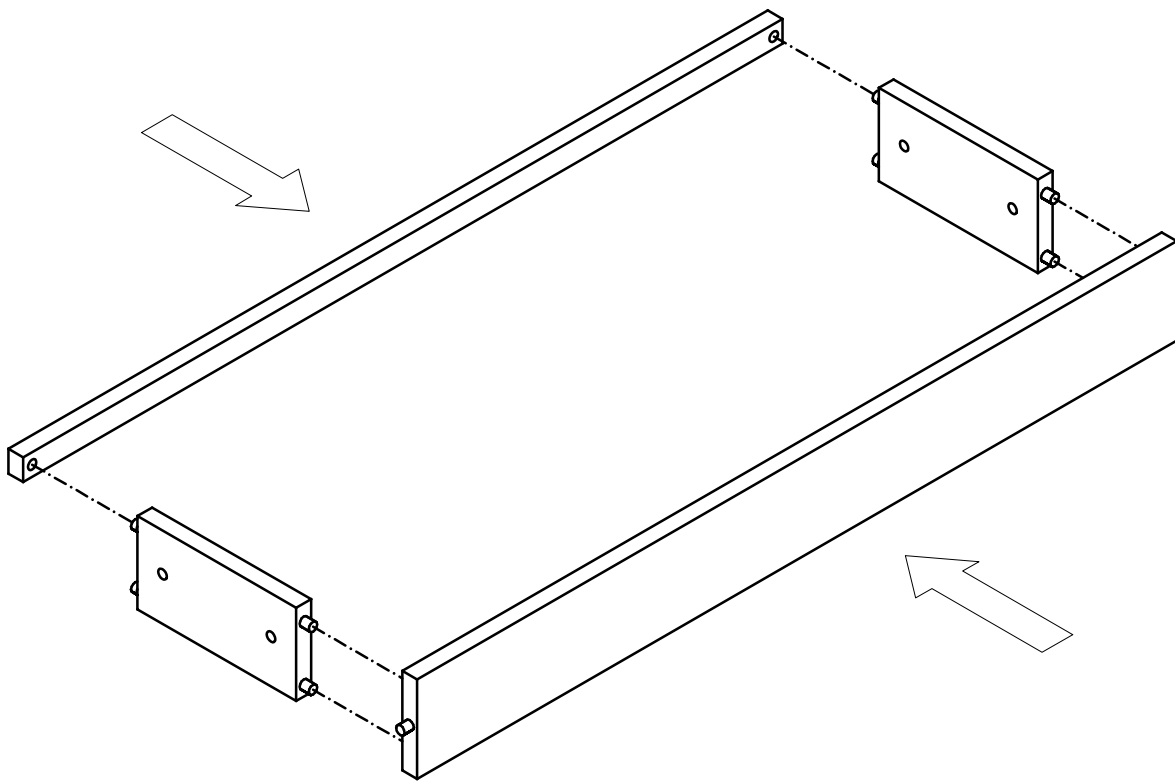

PALMIERI
create. communicate. collaborate.

T 905 731 9300
F 905 731 9878
TF 800 413 4440

www.palmierifurniture.com

2 - GABLE ASSEMBLY

Starter

Install (2) Female Beta Clips To Each Gable Using (2) #6x5/8"L Pan Head Bronze Screws.

Install Toe Kick/Rail Assembly To Both Gables Using (4) 1/4-20x2"L Threaded Rods With Serrated Flange Nuts And (2) Factory Installed Wood Dowels.

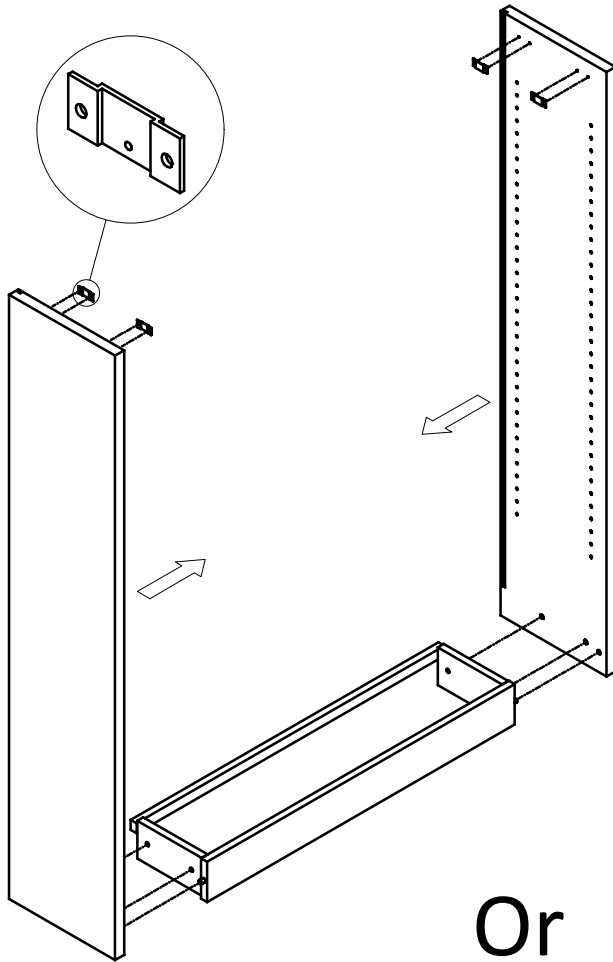

Or

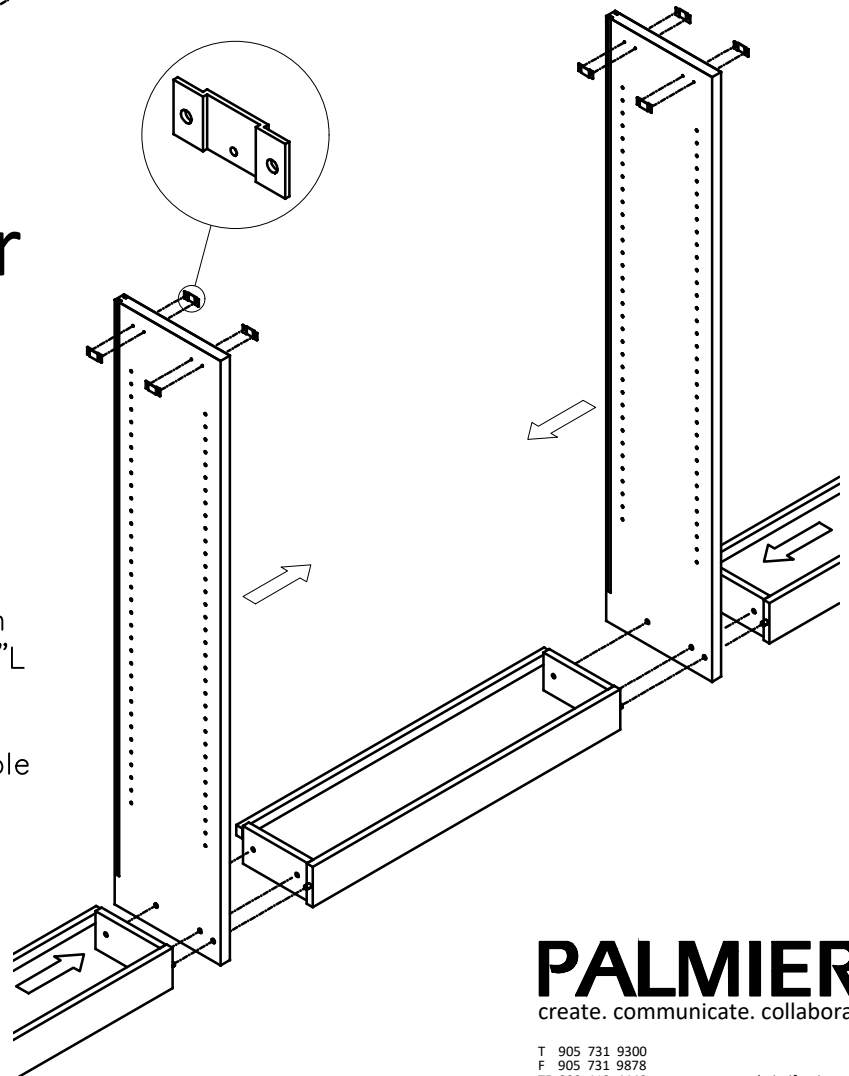

Add-On

Install (2) Female Beta Clips To Each Side Of The Gable Using (2) #6x5/8"L Pan Head Bronze Screws.

Install Toe Kick/Rail Assembly To Gable Using (2) 1/4-20x4" Threaded Rods With Serrated Flange Nuts And (2) Factory Install Wood Dowels.

PALMIERI
create. communicate. collaborate.

T 905 731 9300
F 905 731 9878
TF 800 413 4440

www.palmierifurniture.com

3 - BACK & BOTTOM ASSEMBLY

Starter And Add-On

Place Bottom Onto Toe Kick/Rail Assembly.

Install Back Panel Into Gable Grooves And Slide Down Into The Groove In The Bottom.

Secure Bottom To Toe Kick/Rail Assembly Using (2) #8x1 1/2"L Flat Head Screws.

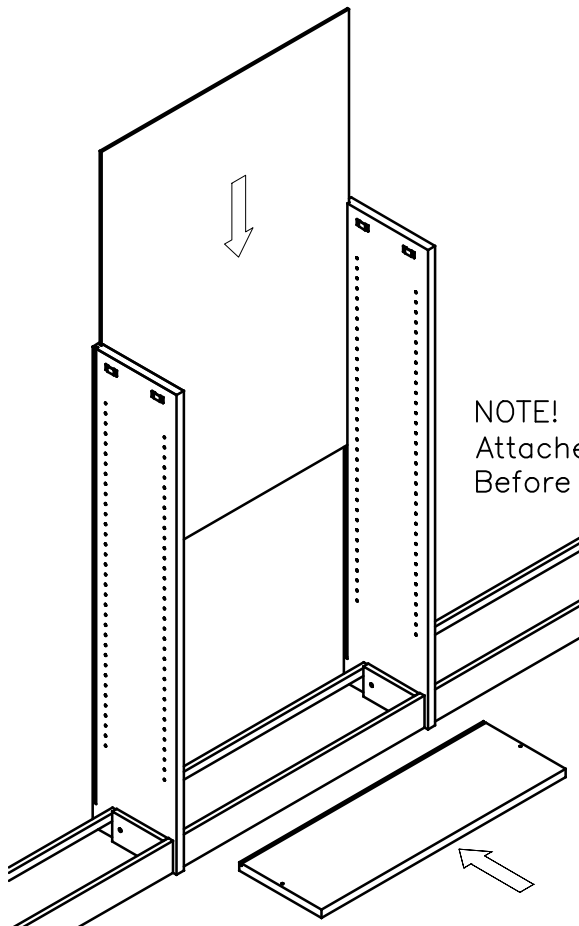
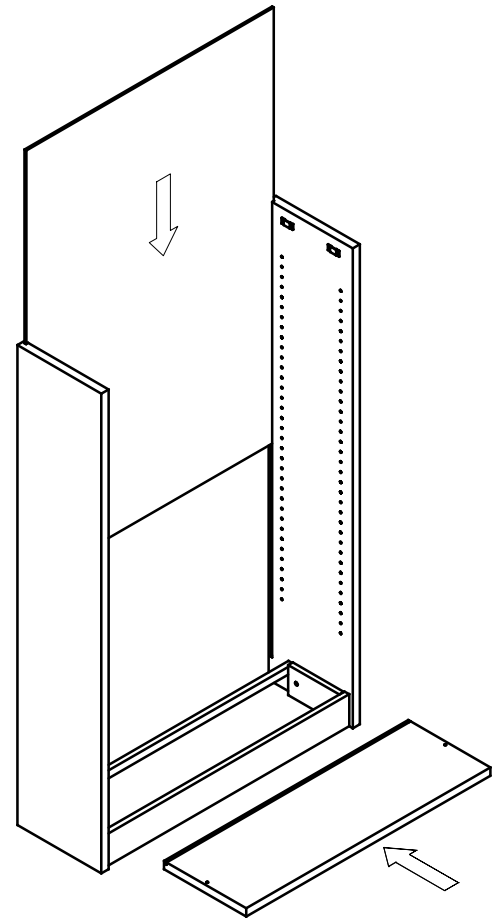

NOTE! Toe Kick/Rail Assembly Must Be Attached To Both Sides Of The Gable Before Bottom And Back Are Installed.

PALMIERI
create. communicate. collaborate.

T 905 731 9300
F 905 731 9878
TF 800 413 4440

www.palmierifurniture.com

4 - TOP ASSEMBLY

Starter And Add-On

Install (4) Male Beta Clips Onto
Top/Valance Assembly Using (2)
#6x5/8"L Pan Head Bronze Screws.

Assemble Top To Gables Using The Beta
Clips. Ensure The Back Panel Is Fitted
Into The Groove On The Underside Of
The Top.

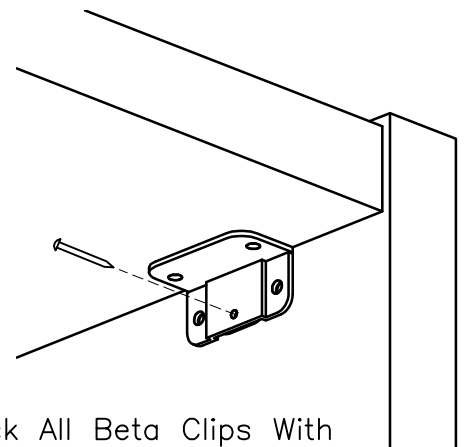
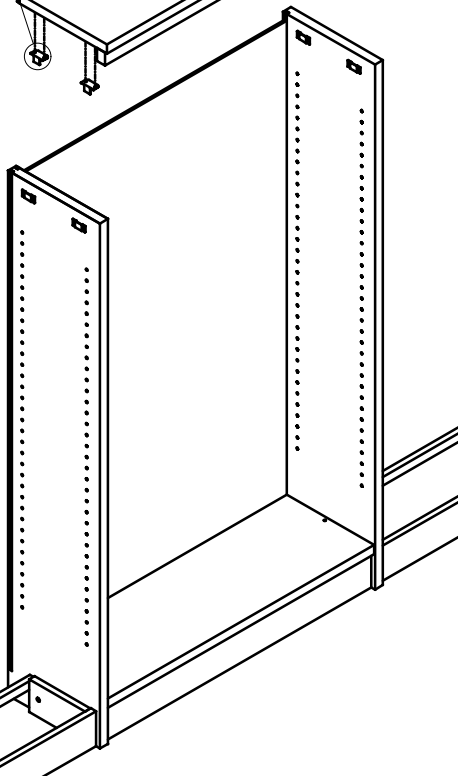
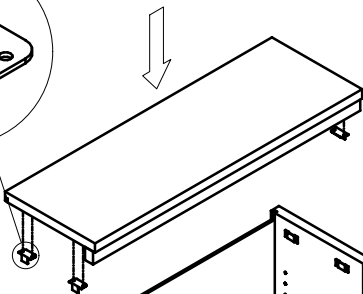
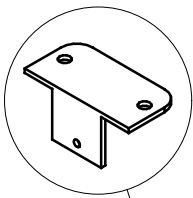
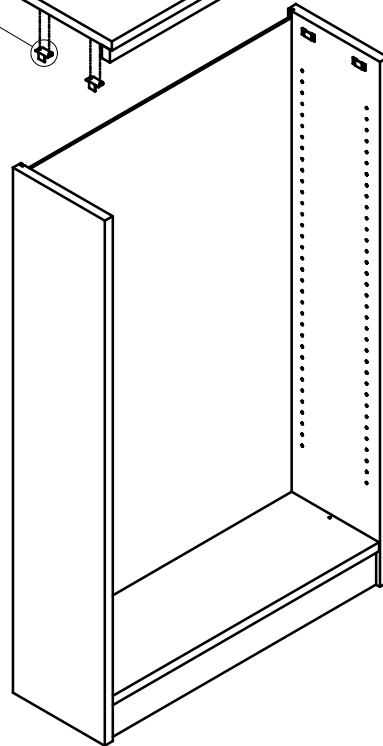
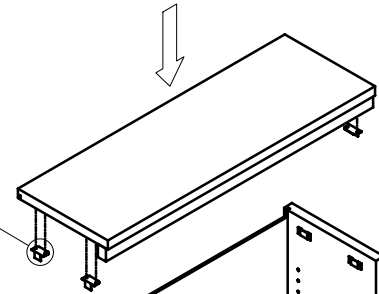
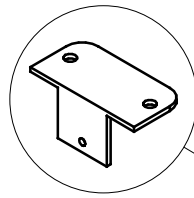

Lock All Beta Clips With
(1) 1" Finishing Nail.

PALMIERI
create. communicate. collaborate.

T 905 731 9300
F 905 731 9878
TF 800 413 4440

www.palmierifurniture.com

5A - FIXED WOOD SHELF ASSEMBLY

FOR WOOD SHELVING UNITS 60"H AND TALLER, ONLY

(SKIP THIS STEP IF YOUR SHELVING UNITS ARE SHORTER THAN 60"H)

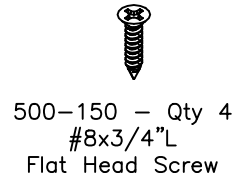
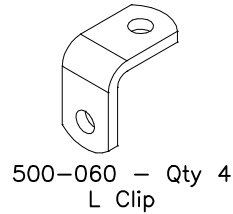
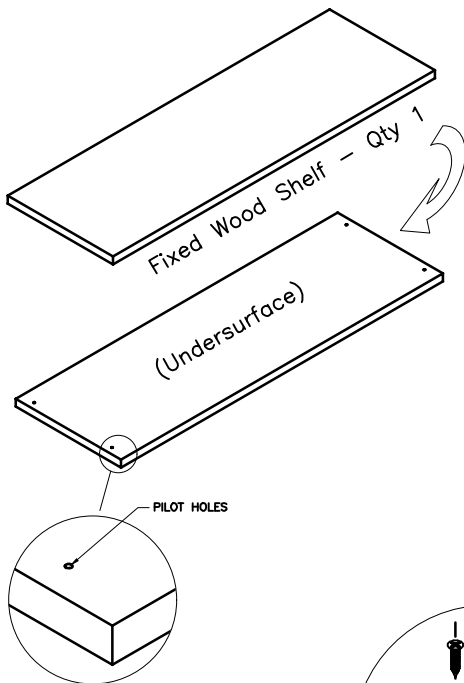

Starter And Add-On

Install (4) L Clips To Fixed Wood Shelf Using #8x3/4"L Flat Head Screw.

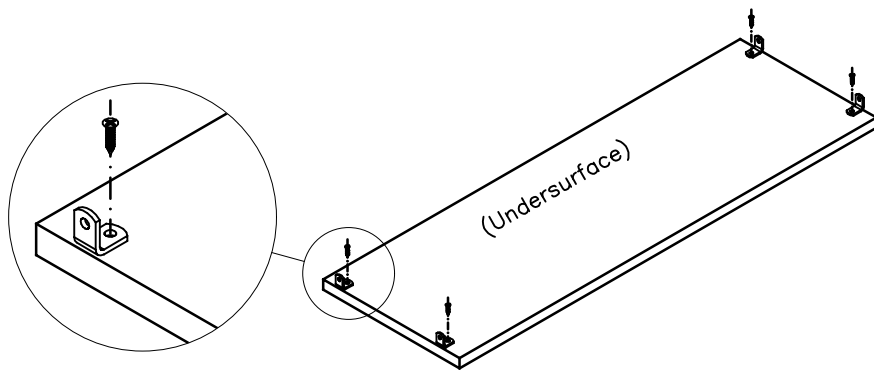

Install Fixed Wood Shelf To Gables Using (4) 5mm Euro Screws Into Existing Adjustable Shelf Pin Holes. Fixed Wood Shelf To Be Placed At Center Of The Gable Height $\pm 2 \frac{1}{2}$ ".

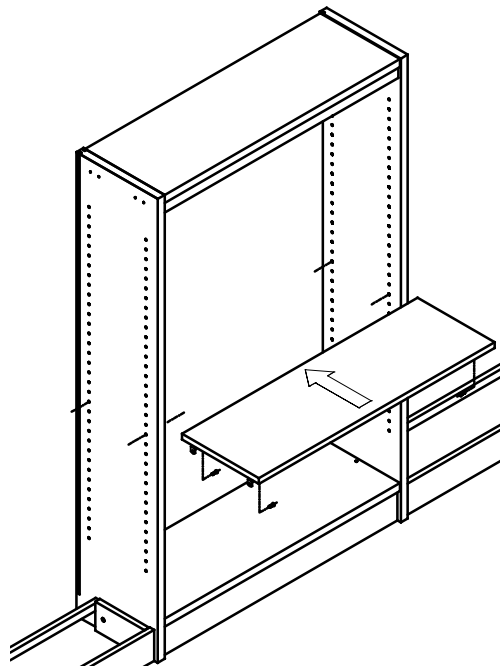
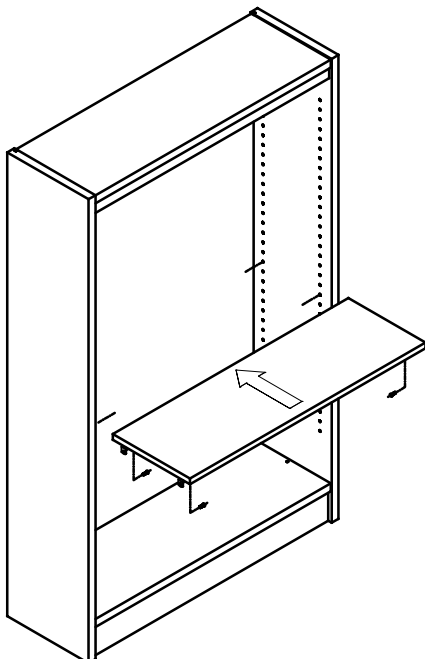

PALMIERI
create. communicate. collaborate.

T 905 731 9300
F 905 731 9878
TF 800 413 4440

www.palmierifurniture.com

6 - ADJUSTABLE SHELF ASSEMBLY

Starter And Add-On

Install Threaded Adjustable Shelf Pins (4 Per Shelf) Into The Gables. Place Adjustable Shelf (Shelves) On Pins.

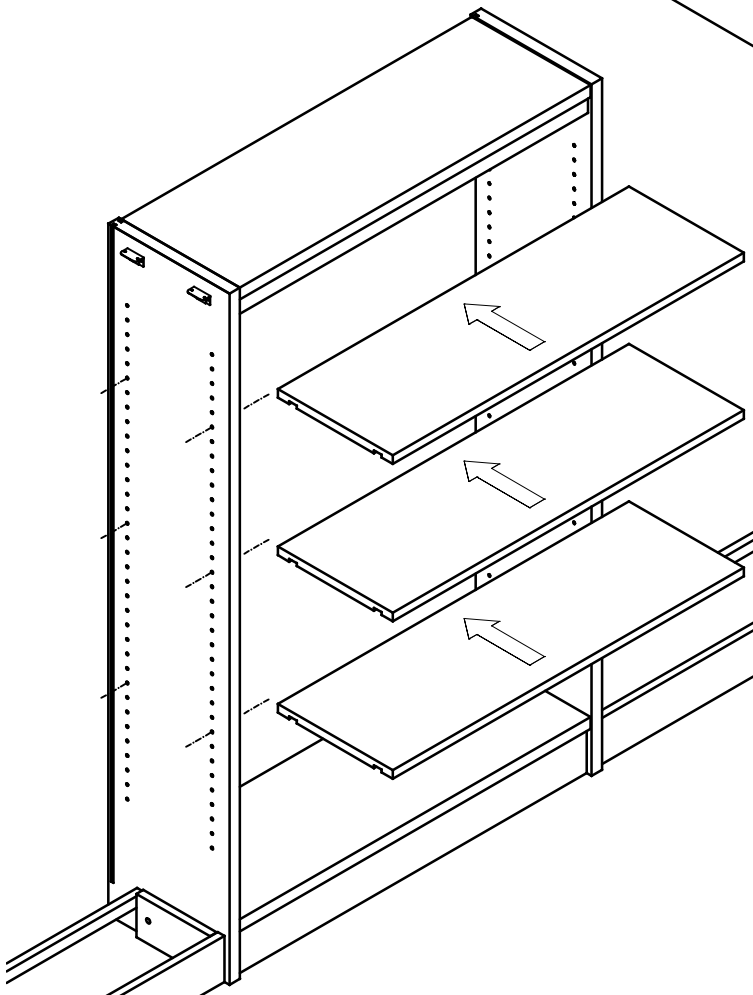
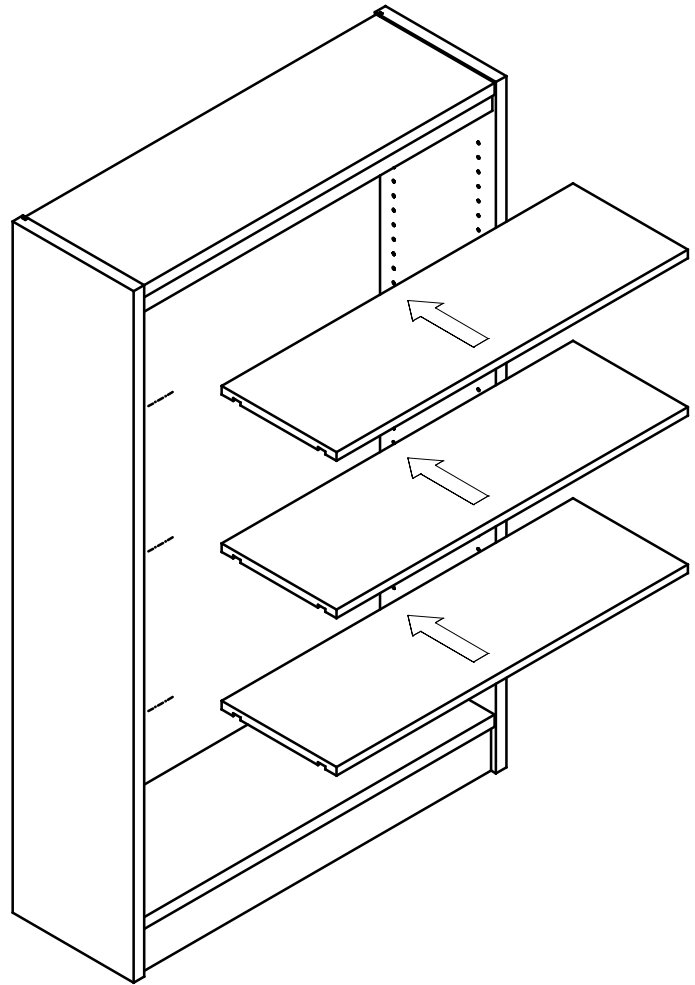

PALMIERI
create. communicate. collaborate.

T 905 731 9300
F 905 731 9878
TF 800 413 4440

www.palmierifurniture.com

7

Starter

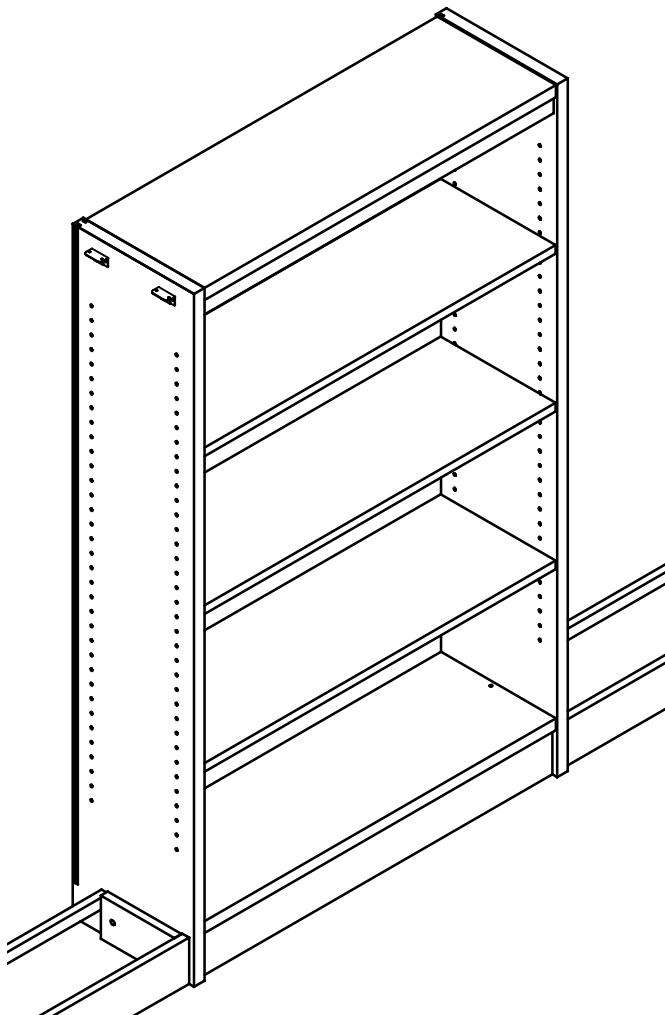
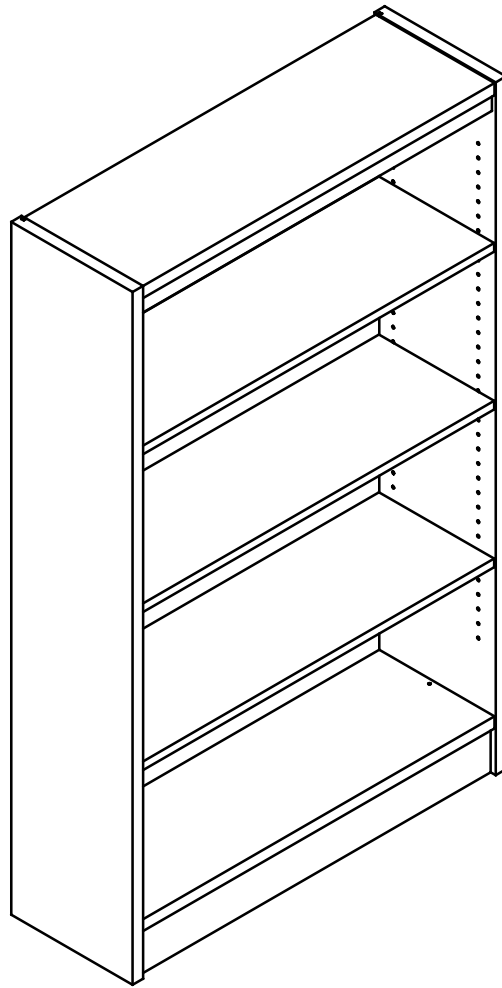

Add-On

PALMIERI
create. communicate. collaborate.

T 905 731 9300
F 905 731 9878
TF 800 413 4440

www.palmierifurniture.com